



995 Governor Dr. #103
El Dorado Hills, CA 95762

866 382-8600

YARDART info@yardart.com

Low Wolcott Pedestal



PD-203 shown with P-600 in Alpine Stone

Cast Stone

Campania proudly manufactures its cast stone products in the USA using locally sourced materials. All of our cast stone pieces are manufactured using the wet casting technique with a proprietary high density cast stone mix, yielding a PSI strength of approximately 7,500. The mix is comprised primarily of water, sand, stone aggregate and cement. Our cast stone products may qualify for LEED credits as applicable to your project. Cast stone produces a strong and durable product that will weather naturally in an outdoor environment. Simply stated, cast stone is chosen for its beauty and authenticity. Our material is natural, authentic, made in the USA, and 100% recyclable. These planters are often specified for hospitality projects, large scale public space installations, pedestrian and traffic safety, and other custom projects. Although we recommend that you take advantage of the quick turnaround of our stocked product; these shapes, finishes, and/or sizes are not always right for every job. Campania has the capability to produce custom molds and colors in our Pennsburg, PA factory.

Available in a choice of thirteen (13) exclusive natural pigment stains in addition to natural. All of our patinas are hand applied in a multi-step process which produces unique and beautiful surface finishes. Designed to replicate the look of naturally aged materials, the patinas will not prevent the natural aging process that occurs in an outdoor environment. Rather than creating uniform stains, our approach gives our products their unique beauty and appeal.

Material	Item Description	Item #	Outside Dimensions	Base Dimensions	Top Usable Surface	Approx. Weight	Drainage Hole
Cast Stone	Low Wolcott Pedestal	PD-203	9.5" Sq. x 12.5"H	9.5" Sq.	9.5" Sq. w/ 3.5" Sq. insert	67 lbs	yes, 2" Diam. centered

AVAILABLE COLORS

Please note: Actual colors may vary slightly from those depicted below. Color samples are available upon request. Call 215-541-4627 for more info.

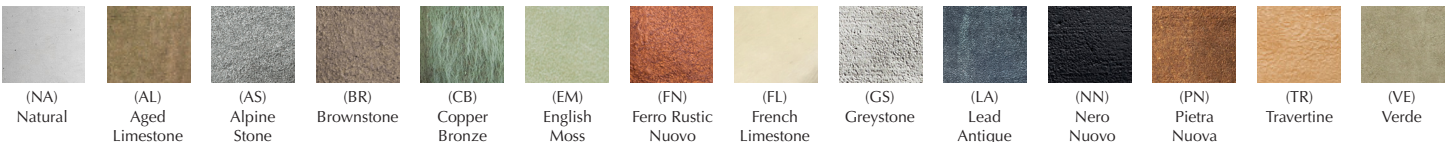

Low Wolcott Pedestal

Isometric View

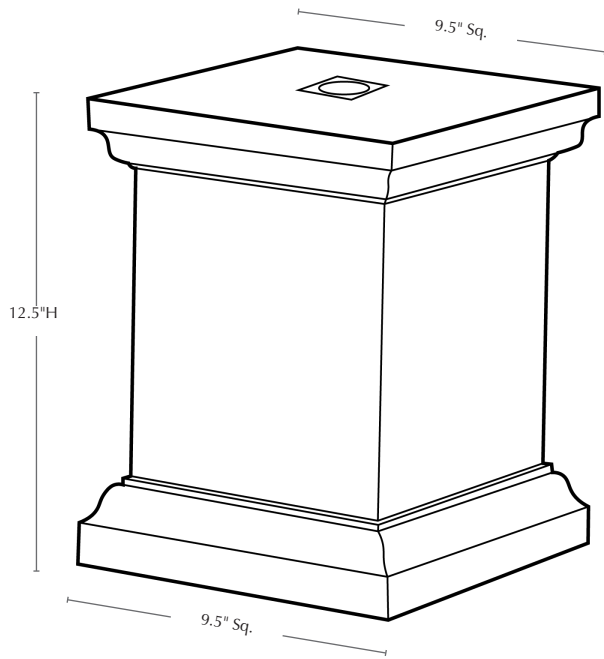

Top View

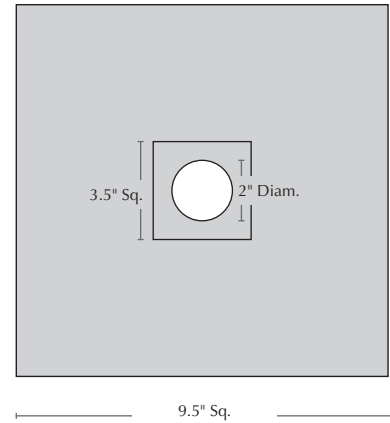

Materials: cement, sand, stone aggregate and water

Touch-up & Patch Kits: Available upon request by calling 215.541.4627.

Cleaning Instructions: Campania's cast stone pedestals can be cleaned with diluted vinegar and water or with any commercially available mild detergent. Use a soft cloth, sponge, or brush. Do not pressure wash, apply corrosive cleaners or clean with anything abrasive. Note that it may take several cycles of wiping and drying before the pedestal is completely clean. Cast stone contains salts that may effloresce over time. You will notice a fine white powdery coating on the surface of the cast stone if the efflorescence is present in your product. If you wish to remove the salt deposits, Campania can recommend an appropriate an efflorescence cleaner. Contact us at 215-541-4627 for details.